

Interference of Light

1 Mark Questions

1. Define the term 'coherent sources' which are required to produce interference pattern in Young's double slit experiment. [Delhi 2014 c]

Ans. Two monochromatic sources, which produce light waves, having a constant phase difference are known as coherent sources.

2. How would the angular separation of interference fringes in Young's double slit experiment change when the distance between the slits and screen is halved? [All India 2009]

Ans.

The angular separation of interference fringes in Young's double slit experiment becomes double when separation between slits and screen is halved as angular separation,

$$\theta \propto \frac{1}{D} \quad (1)$$

3. Why are coherent sources required to create interference of light? [Foreign 2009]

Ans. To observe interference fringe pattern, there is need to have coherent sources of light which can produce light of constant phase difference

4. How does the fringe width of interference fringes change, when the whole apparatus of Young's experiment is kept in a liquid of refractive index, 1.3? [hots; Delhi 2008]

Ans.

 In Young's double slit experiment, fringe width,
$$\beta = \frac{D\lambda}{d}$$

From the formula it is clear that when apparatus is dipped in a liquid then only wavelength λ will change, it will become $\frac{1}{\mu}$ times of its value in air.

The new fringe width becomes $\frac{1}{1.3}$ times of original fringe width as

$$\frac{\beta_{\text{air}}}{\beta_{\text{med}}} = \mu \Rightarrow \beta_{\text{med}} = \frac{\beta_{\text{air}}}{\mu} \quad (1)$$

5. How does the angular separation of interference fringes change, in Young's experiment, if the distance between the slits is increased? [Delhi 2008]



Ans.

Angular separation decreases with the increase of separation between two slits as,

$$\theta = \frac{\lambda}{d}$$

where, d = separation between two slits. (1)

2 Marks Questions

6. Laser light of wavelength 630 nm incident on a pair of slits produces an interference pattern in which the bright fringes are separated by 7.2 mm. Calculate the wavelength of another source of laser light which produce interference fringes separated by 8.1 mm using same pair of slits. [All India 2011]

Ans.

$$\text{Given, } \beta_1 = 7.2 \times 10^{-3} \text{ m, } \beta_2 = 8.1 \times 10^{-3} \text{ m}$$

$$\text{and } \lambda_1 = 630 \times 10^{-9} \text{ m}$$

$$\therefore \text{Fringe width, } \beta = \frac{D\lambda}{d}$$

where, λ = wavelength, D = separation between slits and screen and d = separation between two slits.

$$\Rightarrow \frac{\beta_1}{\beta_2} = \frac{\lambda_1}{\lambda_2} \quad (\because D \text{ and } d \text{ are same}) \quad (1)$$

Wavelength of another source of laser light

$$\begin{aligned} \Rightarrow \lambda_2 &= \frac{\beta_2}{\beta_1} \times \lambda_1 \\ &= \frac{8.1 \times 10^{-3}}{7.2 \times 10^{-3}} \times 630 \times 10^{-9} \text{ m} \end{aligned}$$

$$\text{or } \lambda_2 = 708.75 \times 10^{-9} \text{ m}$$

$$\therefore \lambda_2 = 708.75 \text{ nm} \quad (1)$$

7. How will the interference pattern in Young's double slit experiment get affected, when

(i) distance between the slits S_1 and S_2 reduced and

(ii) the entire set up is immersed in water? Justify your answer in each case. [Delhi 2011]

Ans.

(i) The fringe width of interference pattern increases with the decrease in separation between $S_1 S_2$ as

$$\beta \propto \frac{1}{d} \quad (1)$$

(ii) The fringe width decrease as wavelength gets reduced when interference set up is taken from air to water. (1)

8. The figure shows a double slit experimental set up for observing interference fringes due to different interference component colours of white light.

What would be the predominant colour of the fringes observed at the point

(i) O (the central point)

(ii) P, where, $S_2 P - S_1 P = \frac{\lambda_b}{2}$

(here, λ_b is the wavelength of the blue colour).

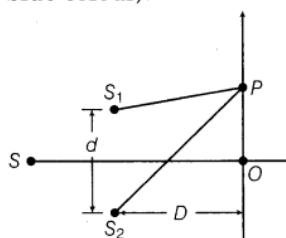

[All India 2009]

Ans. (i) White colour fringe is obtained at point O as all components colour wavelength undergo constructive interference fringe pattern.

(ii) In this case, the light of blue colour interfere destructively and hence this colour would subtract from white light. Thus, yellow colour fringe would be obtained at P.

9. Write down two conditions to obtain the sustained interference fringe pattern of light. What is the effect on the interference fringes in Young's double slit experiment, when monochromatic source is replaced by a source of white light? [Foreign 2008]

Ans. Conditions for sustained interference

- (i) The two sources of light must be coherent to emit light of constant phase difference.
- (ii) The amplitude of electric field vector of interfering wave should be equal to have greater contrast between intensity of constructive and destructive interference.

When monochromatic light is replaced by white light, then coloured fringe pattern is obtained on the screen

3 Marks Questions

10. (a) Two monochromatic waves emanating from two coherent sources have the displacements represented by

$$y_1 = a \cos \omega t$$

$$\text{and } y_2 = a \cos(\omega t + \phi),$$

where ϕ is the phase difference between the two waves. Show that the resultant intensity at a point due to their superposition is given by $I = 4I_0 \cos^2 \phi / 2$, where $I_0 = a^2$.

(b) Hence, obtain the conditions for constructive and destructive interference. [All India 2014C]

Ans.

Given,

$$y_1 = a \cos \omega t$$

$$y_2 = a \cos(\omega t + \phi)$$

(a) The resultant displacement is given by

$$\begin{aligned} Y &= y_1 + y_2 \\ &= a \cos \omega t + a \cos(\omega t + \phi) \\ &= a \cos \omega t + a \cos \omega t \cos \phi - a \sin \omega t \sin \phi \\ &= a \cos \omega t (1 + \cos \phi) - a \sin \omega t \sin \phi \end{aligned}$$

$$\text{Put } R \cos \theta = a(1 + \cos \phi) \quad \dots(i)$$

$$R \sin \theta = a \sin \phi \quad \dots(ii)$$

By squaring and adding Eqs. (i) and (ii), we get

$$\begin{aligned} R^2 &= a^2(1 + \cos^2 \phi + 2 \cos \phi) + a^2 \sin^2 \phi \\ &= 2a^2(1 + \cos \phi) \\ &= 4a^2 \cos^2 \frac{\phi}{2} \end{aligned}$$

$$\begin{aligned} \therefore I &= R^2 = 4a^2 \cos^2 \frac{\phi}{2} \\ &= 4I_0 \cos^2 \frac{\phi}{2} \end{aligned}$$

(b) For constructive interference,

$$\cos \frac{\phi}{2} = \pm 1 \text{ or}$$

$$\frac{\phi}{2} = n\pi \text{ or}$$

$$\phi = 2n\pi$$

For destructive interference,

$$\cos \frac{\phi}{2} = 0 \text{ or}$$

$$\frac{\phi}{2} = (2n + 1) \frac{\pi}{2} \text{ or}$$

$$\phi = (2n + 1)\pi$$

11. Describe Young's double slit experiment to produce interference pattern due to a monochromatic source of light. Deduce the expression for the fringe width. [Delhi 2011]

Ans.

Let two coherent sources of light, S_1 and S_2 (narrow slits) are derived from a source S . The two slits, S_1 and S_2 are equidistant from source, S .

Now, suppose S_1 and S_2 are separated by distance d . The slits and screen are distance D apart.

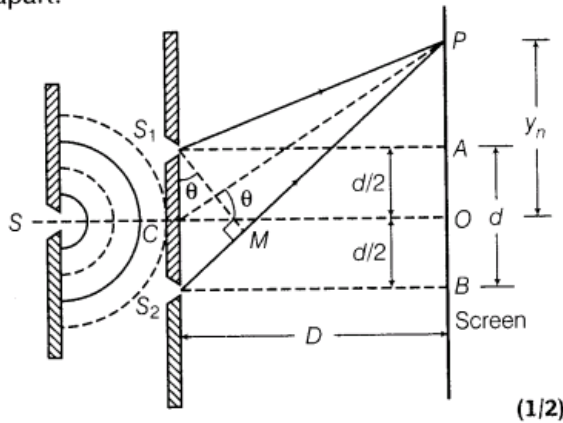

Considering any arbitrary point P on the screen at a distance y_n from the centre O . The path difference between interfering waves is given by $S_2P - S_1P$

i.e. Path difference = $S_2P - S_1P = S_2M$
 $S_2P - S_1P = d \sin \theta$

where, $S_1M \perp S_2P$ (1)

[$\because \angle S_2S_1M = \angle OCP$ (by geometry)]

$\Rightarrow S_1P = PM \Rightarrow S_2P = S_2M$

If θ is small, then $\sin \theta \approx \theta \approx \tan \theta$

\therefore Path difference,

$S_2P - S_1P = S_2M = d \sin \theta \approx d \tan \theta$

Path difference = $d \left(\frac{y_n}{D} \right)$... (i)

[\because In ΔPCO , $\tan \theta = \frac{OP}{CO} = \frac{y_n}{D}$]

For constructive interference

Path difference = $n\lambda$, where, $n = 0, 1, 2, \dots$

$\frac{dy_n}{D} = n\lambda$ [from Eq. (i)]

$\Rightarrow y_n = \frac{Dn\lambda}{d}$

$\Rightarrow y_{n+1} = \frac{D(n+1)\lambda}{d}$

\therefore Fringe width of dark fringe = $y_{n+1} - y_n$

[\because Dark fringe exist between two bright fringes]

$\beta = \frac{D\lambda}{d}(n+1) - \frac{Dn\lambda}{d} = \frac{d\lambda}{d}(n+1-n) = \frac{D\lambda}{d}$

Fringe width of dark fringe, $\beta = \frac{D\lambda}{d}$... (ii)

For destructive interference

Path difference = $(2n - 1) \frac{\lambda}{2}$, where $n = 1, 2, 3, \dots$

$$\Rightarrow \frac{y'_n d}{D} = (2n - 1) \frac{\lambda}{2} \quad [\text{from Eq. (i)}]$$

$$\Rightarrow y'_n = \frac{(2n - 1) D \lambda}{2d}$$

where, y'_n is the separation of n th order dark fringe from central fringe.

$$\therefore y'_{n+1} = (2n + 1) \frac{D\lambda}{2d} \quad (1)$$

\therefore Fringe width of bright fringe = Separation between $(n + 1)$ th and n th order dark fringe from centred fringe,

$$\Rightarrow \beta = y'_{n+1} - y'_n$$

$$\begin{aligned} \text{or } \beta &= \frac{(2n + 1) D\lambda}{2d} - \frac{(2n - 1) D\lambda}{2d} \\ &= \frac{D\lambda}{2d} [2n + 1 - 2n + 1] = \frac{D\lambda}{2d} \quad [2] \end{aligned}$$

Fringe width of bright fringe, $\beta = \frac{D\lambda}{d}$... (iii)

From Eqs. (ii) and (iii), we can see that, fringe width of dark fringe = fringe width of bright fringe

$$\beta = \frac{D\lambda}{d} \quad (1/2)$$

- 12.** The intensity at the central maxima (O) in a Young's double slit experiment is I_0 . If the distance OP equals one-third of fringe width of the pattern, then show that the intensity at point P would be $I_0/4$.

[HOTS; Foreign 2011]

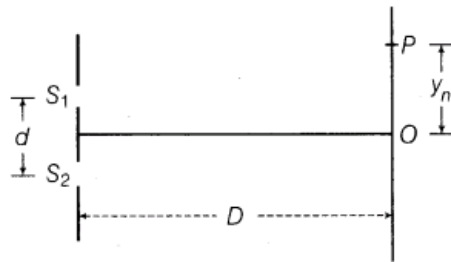

Ans.

Intensity can be found out if, we know the phase difference. Phase difference can be calculated with the help of path difference. So first of all, path difference will be calculated.

Given, $OP = y_n$

The distance OP equals one-third of fringe width of the pattern

$$\begin{aligned} \text{i.e. } y_n &= \frac{\beta}{3} = \frac{1}{3} \left(\frac{D\lambda}{d} \right) = \frac{D\lambda}{3d} \\ \Rightarrow \frac{dy_n}{D} &= \frac{\lambda}{3} \end{aligned} \quad (1)$$

$$\text{Path difference, } S_2P - S_1P = \frac{dy_n}{D} = \frac{\lambda}{3}$$

Now for phase difference corresponding to path difference.

$$\begin{aligned} \text{Phase difference} &= \frac{2\pi}{\lambda} \times \text{Path difference} \\ &= \frac{2\pi}{\lambda} \times \frac{\lambda}{3} \end{aligned}$$

$$\therefore \text{Phase difference} = \frac{2\pi}{3} \quad (1)$$

If intensity at central fringe is I_0 , then intensity at a point, P where phase difference is ϕ , is given by

$$\begin{aligned} I &= I_0 \cos^2 \phi \\ \Rightarrow I &= I_0 \left(\cos \frac{2\pi}{3} \right)^2 = I_0 \left(-\cos \frac{\pi}{3} \right)^2 \\ &= I_0 \left(-\frac{1}{2} \right)^2 = \frac{I_0}{4} \end{aligned}$$

Hence, the intensity at point P would be $\frac{I_0}{4}$. (1)

13. In Young's double slit experiment, the two slits 0.15 mm apart are illuminated by monochromatic light of wavelength 450 nm. The screen is 0 m away from the slits.

(i) Find the distance of the second

- bright fringe
- dark fringe from the central maximum.

(ii) How will the fringe pattern change if the screen is moved away from the slits? [All India 2010]

Ans.

Distance between the two sources

$$d = 0.15 \text{ mm} = 1.5 \times 10^{-4} \text{ m}$$

Wavelength, $\lambda = 450 \text{ nm} = 4.5 \times 10^{-7} \text{ m}$

Distance of screen from source, $D = 1 \text{ m}$

(i) (a) The distance of n th order bright fringe from central fringe is given by

$$y_n = \frac{Dn\lambda}{d}$$

For second bright fringe,

$$y_2 = \frac{2D\lambda}{d}$$

$$y_2 = \frac{2 \times 1 \times 4.5 \times 10^{-7}}{1.5 \times 10^{-4}}$$

$$y_2 = 6 \times 10^{-3} \text{ m}$$

The distance of the second bright fringe

$$y_2 = 6 \text{ mm} \quad (1)$$

(b) The distance of n th order dark fringe from central fringe is given by

$$y'_n = (2n - 1) \frac{D\lambda}{2d}$$

For second dark fringe, $n = 2$

$$y'_n = (2 \times 2 - 1) \frac{D\lambda}{2d} = \frac{3D\lambda}{2d}$$

$$y'_n = \frac{3}{2} \times \frac{1 \times 4.5 \times 10^{-7}}{1.5 \times 10^{-4}}$$

The distance of the second dark fringe,

$$y'_n = 4.5 \text{ mm} \quad (1)$$

(ii) With increase of D , fringe width increases as

$$\beta = \frac{D\lambda}{d} \quad \text{or} \quad \beta \propto D \quad (1)$$

14. A beam of light consisting of two wavelengths 560 nm and 420 nm is used to obtain interference fringes in a Young's double slit experiment. Find the least distance from the central maximum, where the bright fringes, due to both the wavelengths coincide. The distance between the two slits is 4.0 mm and the screen is at a distance of 0 m from the slits. [Delhi 2010 C]

Ans.



To find the point of coincidence of bright fringes, we can equate the distance of bright fringes from the central maxima, made by both the wavelengths of light

Given, $D = 1 \text{ m}$, $d = 4 \times 10^{-3} \text{ m}$, $\lambda_1 = 560 \text{ nm}$, and $\lambda_2 = 420 \text{ nm}$

Let n th order bright fringe of λ_1 coincides with $(n + 1)$ th order bright fringe of λ_2 .

$$\Rightarrow \frac{Dn\lambda_1}{d} = \frac{D(n+1)\lambda_2}{d} \quad (\lambda_1 > \lambda_2)$$



$$\Rightarrow n\lambda_1 = (n+1)\lambda_2 \quad (1)$$

$$\Rightarrow \frac{n+1}{n} = \frac{\lambda_1}{\lambda_2}$$

$$1 + \frac{1}{n} = \frac{560 \times 10^{-9}}{420 \times 10^{-9}}$$

$$\Rightarrow 1 + \frac{1}{n} = \frac{4}{3}$$

$$\Rightarrow \frac{1}{n} = \frac{1}{3} \Rightarrow n = 3 \quad (1)$$

\therefore Least distance from the central fringe where bright fringe of two wavelength coincides.

= Distance of 3rd order bright fringe of λ_1

$$\Rightarrow y_n = \frac{3D\lambda_1}{d}$$

$$= \frac{3 \times 1 \times 560 \times 10^{-9}}{4 \times 10^{-3}}$$

$$y_n = 420 \times 10^{-6} \text{ m}$$

$$= 0.42 \times 10^{-3} \text{ m}$$

$$\therefore y_n = 0.42 \text{ mm} \quad (1)$$

Thus, 3rd bright fringe of λ_1 and 4th bright fringe of λ_2 coincide at 0.42 mm from central fringe.

15.A beam of light consisting of two wavelengths 600 nm and 450 nm is used to obtain interference fringes in a Young's double slit experiment. Find the least distance from the central maxima, where the bright fringes due to both the wavelengths coincide. The distance between the two slits is 4 mm and the screen is at a distance 1m from the slits. [Foreign 2008]

Ans.

Given, $D = 1 \text{ m}$, $d = 4 \times 10^{-3} \text{ m}$, $\lambda_1 = 600 \text{ nm}$,

and $\lambda_2 = 450 \text{ nm}$

Let n th order bright fringe of λ_1 coincides with $(n+1)$ th order bright fringe of λ_2

$$\text{i.e. } \frac{Dn\lambda_1}{d} = \frac{D(n+1)\lambda_2}{d}$$

$$\Rightarrow \frac{\lambda_1}{\lambda_2} = \frac{n+1}{n}$$

$$\frac{\lambda_1}{\lambda_2} = 1 + \frac{1}{n}$$

$$\Rightarrow 1 + \frac{1}{n} = \frac{600 \times 10^{-9}}{450 \times 10^{-9}} = \frac{4}{3}$$

$$\Rightarrow n = 3 \quad (1)$$

The separation of 3rd order bright fringe from central fringe of $\lambda_1 = 600 \text{ nm}$ will be the least distance from central fringe, where 4th bright fringe of $\lambda_2 = 450 \text{ nm}$ coincides.

$$\text{As, } y_n = \frac{Dn\lambda_1}{d}$$

For $n = 3$ (1)

$$y_3 = \frac{1 \times 3 \times 600 \times 10^{-9}}{4 \times 10^{-3}}$$

$$= 4.5 \times 10^{-4}$$

$$= 0.45 \times 10^{-3} \text{ m}$$

$$y_3 = 0.45 \text{ mm} \quad (1)$$

Thus, 3rd bright fringe of λ_1 and 4th bright fringe of λ_2 coincide at 0.45 mm from central fringe.

16. In Young's double slit experiment, monochromatic light of wavelength 630 nm illuminates the pair of slits and produces an interference pattern in which two consecutive bright fringes are separated by 1 mm. Another source of monochromatic light produces the interference pattern in which the two consecutive bright fringes are separated by 7.2 mm. Find the wavelength of light from the second source. What is the effect on the interference fringes, is when monochromatic source is replaced by a source of white light? [All India 2009]

Ans.

 The separation between two consecutive bright fringes gives fringe width (β) of dark fringe and vice-versa.

Fringe width,

$$\beta = \frac{D\lambda}{d}$$

For given Young's double slit experiment, D and d are constants.

$$\Rightarrow \frac{\beta_1}{\beta_2} = \frac{\lambda_1}{\lambda_2} \quad \dots(i)$$

as $\frac{D}{d} = \text{constant}$

Here, $\beta_1 = 8.1 \times 10^{-3} \text{ m}$

$$\lambda_1 = 630 \text{ nm} = 630 \times 10^{-9} \text{ m} \quad (1)$$

$$\beta_2 = 7.2 \times 10^{-3} \text{ m}$$

$$\therefore \frac{\beta_1}{\beta_2} = \frac{\lambda_1}{\lambda_2} \quad (1)$$

Wavelength of light from the second source

$$\Rightarrow \lambda_2 = \frac{\beta_2}{\beta_1} \times \lambda_1$$

$$= \frac{7.2 \times 10^{-3}}{8.1 \times 10^{-3}} \times 630 \times 10^{-9}$$

$$= \frac{8}{9} \times 630 \times 10^{-9}$$

$$= 560 \times 10^{-9} \text{ m}$$

$$\lambda_2 = 560 \text{ nm} \quad (1)$$

The coloured fringe pattern would be obtained, if monochromatic light is replaced by white light.



17. In Young's double slit experiment, monochromatic light of wavelength 600 nm illuminates the pair of slits and produces an interference pattern in which two consecutive bright fringes are separated by 10 mm. Another source of monochromatic light produces the interference pattern in which the two consecutive bright fringes are separated by 8 mm. Find the wavelength of light from the second source. What is the effect on the interference fringes if the monochromatic source is replaced by a source of white light? [All India 2009]

Ans.

 The separation between two consecutive bright fringes gives fringe width (β) of dark fringe and vice-versa.

Fringe width,

$$\beta = \frac{D\lambda}{d}$$

For given Young's double slit experiment, D and d are constants.

$$\Rightarrow \frac{\beta_1}{\beta_2} = \frac{\lambda_1}{\lambda_2} \quad \dots(i)$$

as $\frac{D}{d} = \text{constant}$

Here, $\beta_1 = 8.1 \times 10^{-3} \text{ m}$

$$\lambda_1 = 630 \text{ nm} = 630 \times 10^{-9} \text{ m} \quad (1)$$

$$\beta_2 = 7.2 \times 10^{-3} \text{ m}$$

$$\therefore \frac{\beta_1}{\beta_2} = \frac{\lambda_1}{\lambda_2} \quad (1)$$

Wavelength of light from the second source

$$\begin{aligned} \Rightarrow \lambda_2 &= \frac{\beta_2}{\beta_1} \times \lambda_1 \\ &= \frac{7.2 \times 10^{-3}}{8.1 \times 10^{-3}} \times 630 \times 10^{-9} \\ &= \frac{8}{9} \times 630 \times 10^{-9} \\ &= 560 \times 10^{-9} \text{ m} \\ \lambda_2 &= 560 \text{ nm} \quad (1) \end{aligned}$$

The coloured fringe pattern would be obtained, if monochromatic light is replaced by white light.

Wavelength of light from the second source

$$\lambda_2 = \frac{\beta_2}{\beta_1} \times \lambda_1 = \frac{8 \times 10^{-3}}{10 \times 10^{-3}} \times 600 \times 10^{-9} \quad (1)$$

$$\lambda_2 = 480 \times 10^{-9} \text{ m}$$

$$\lambda_2 = 480 \text{ nm} \quad (1)$$

18. In a Young's double slit experiment, the two slits are kept 2 mm apart and the screen is positioned 140 cm away from the plane of the slits. The slits are illuminated with light of wavelength 600 nm. Find the distance of the third bright fringe from the central maximum, in the interference pattern obtained on the screen. If the wavelength of the incident light were changed to 480 nm, then find out the shift in the position of third bright fringe from the



central maximum.[HOTS; All India 2008]

Ans.

Here, the only factor that is changing is wavelength. So, the shift in the position of third bright fringe will take place due to change in wavelength.

Given, $d = 2 \times 10^{-3}$ m, $D = 140$ cm = 1.4 m
and $\lambda = 600 \times 10^{-9}$ m

The separation of n th order bright fringe from

central fringe is given by, $y_n = \frac{Dn\lambda}{d}$ (1)

For 3rd order bright fringe

$$y_3 = \frac{1.4 \times 3 \times 600 \times 10^{-9}}{2 \times 10^{-3}}$$
$$= 1.26 \times 10^{-3} \text{ m} \quad (1)$$

$$y_3 = 1.26 \text{ mm}$$

For wavelength, $\lambda = 480$ nm

For shift of fringe, $\Delta y = \frac{Dn\Delta\lambda}{d}$

where, $\Delta\lambda = (480 - 600) \text{ nm} = -120 \text{ nm}$
 $= -120 \times 10^{-9} \text{ m}$

Negative sign indicates that shift take place toward central fringe. The magnitude of shift is given by

$$\Delta y = \frac{1.4 \times 3 \times 120 \times 10^{-9}}{2 \times 10^{-3}}$$
$$= 252 \times 10^{-6} = 0.252 \times 10^{-3} \text{ m}$$
$$\Delta y = 0.252 \text{ mm} \quad (1)$$

19. In Young's double slit experiment, interference fringes are observed on a screen a distance kept at D from the slits. If the screen is moved towards the slits by 5×10^{-2} m, the change in fringe width is found to be 3×10^{-5} m. If the separation between the slits is 10^{-3} m, calculate the wavelength of the light used. [Delhi 2006C]

Ans.

Given, $d = 10^{-3}$ m, $\Delta\beta = -3 \times 10^{-5}$ m,
 $\Delta D = -5 \times 10^{-2}$ m

\therefore Fringe width, $\beta = \frac{D\lambda}{d}$

Negative sign indicate that fringe width and D decreases.

$$\Rightarrow \Delta\beta = \frac{\lambda}{d} \Delta D \quad (\text{for same } \lambda \text{ and } d) \quad (1)$$

$$\Rightarrow \lambda = \frac{d \times \Delta\beta}{\Delta D}$$

where, $\lambda = \frac{10^{-3} \times (-3 \times 10^{-5})}{(-5 \times 10^{-2})}$

$$\lambda = 600 \times 10^{-9} \text{ m}$$

Wavelength of light, $\lambda = 600 \text{ nm}$.

5 Marks Questions

20.(i) In Young's double slit experiment, describe briefly how bright and dark fringes are obtained on the screen kept in front of a double slit. Hence, obtain the expression for the fringe width.

(ii) The ratio of the intensities at minima to the maxima in the Young's double slit experiment is 9:25. Find the ratio of the widths of the two slits. [All India 2014]

Ans.(i)

 Intensity can be found out if, we know the phase difference. Phase difference can be calculated with the help of path difference. So first of all, path difference will be calculated.

Given, $OP = y_n$
The distance OP equals one-third of fringe width of the pattern

$$\text{i.e. } y_n = \frac{\beta}{3} = \frac{1}{3} \left(\frac{D\lambda}{d} \right) = \frac{D\lambda}{3d}$$

$$\Rightarrow \frac{dy_n}{D} = \frac{\lambda}{3} \quad (1)$$

$$\text{Path difference, } S_2P - S_1P = \frac{dy_n}{D} = \frac{\lambda}{3}$$

Now for phase difference corresponding to path difference.

$$\text{Phase difference} = \frac{2\pi}{\lambda} \times \text{Path difference}$$

$$= \frac{2\pi}{\lambda} \times \frac{\lambda}{3}$$

$$\therefore \text{Phase difference} = \frac{2\pi}{3} \quad (1)$$

If intensity at central fringe is I_0 , then intensity at a point, P where phase difference is ϕ , is given by

$$I = I_0 \cos^2 \phi$$

$$\Rightarrow I = I_0 \left(\cos \frac{2\pi}{3} \right)^2 = I_0 \left(-\cos \frac{\pi}{3} \right)^2$$

$$= I_0 \left(-\frac{1}{2} \right)^2 = \frac{I_0}{4}$$

Hence, the intensity at point P would be $\frac{I_0}{4}$. (1)

(ii) Given, $\frac{I_{\min}}{I_{\max}} = \frac{9}{25}$

But $\left[\frac{\sqrt{I_1} - \sqrt{I_2}}{\sqrt{I_1} + \sqrt{I_2}} \right]^2 = \frac{9}{25} \Rightarrow \frac{\sqrt{I_1} - \sqrt{I_2}}{\sqrt{I_1} + \sqrt{I_2}} = \frac{3}{5}$

$$5\sqrt{I_1} - 5\sqrt{I_2} = 3\sqrt{I_1} + 3\sqrt{I_2}$$

$$2\sqrt{I_1} = 8\sqrt{I_2}$$

$$\frac{\sqrt{I_1}}{\sqrt{I_2}} = 4$$

Ratio of intensities $\frac{I_1}{I_2} = \frac{16}{1}$

Ratio of widths of the slits $\frac{d_1}{d_2} = \frac{I_1}{I_2} = \frac{16}{1}$.

- 21.** (i) (a) 'Two independent monochromatic sources of light cannot produce a sustained interference pattern'. Give reason.
- (b) Light waves each of amplitude a and frequency ω emanating from two coherent light sources superpose at a point. If the displacements due to these waves is given by $y_1 = a\cos\omega t$ and $y_2 = a\cos(\omega t + \phi)$ where ϕ is the phase difference between the two, obtain the expression for the resultant intensity at the point.
- (ii) In Young's double slit experiment using monochromatic light of wavelength λ , the intensity of light at a point on the screen where path difference is λ , is K units. Find out the intensity of light at a point where path difference is $\lambda/3$.

Ans.

- (i) (a) Two independent monochromatic sources of light cannot produce a sustained interference pattern because their relative phases are changing randomly. When d is negligibly small fringe width β is proportional to $1/d$ may become too large. Even a single fringe may occupy the screen. Hence, the pattern cannot be detected.

Let two coherent sources of light, S_1 and S_2 (narrow slits) are derived from a source S . The two slits, S_1 and S_2 are equidistant from source, S .

Now, suppose S_1 and S_2 are separated by distance d . The slits and screen are distance D apart.

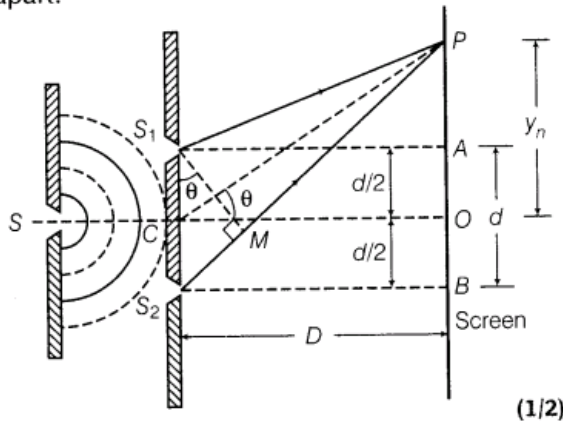

Considering any arbitrary point P on the screen at a distance y_n from the centre O . The path difference between interfering waves is given by $S_2P - S_1P$

i.e. Path difference = $S_2P - S_1P = S_2M$
 $S_2P - S_1P = d \sin \theta$

where, $S_1M \perp S_2P$ (1)

[$\because \angle S_2S_1M = \angle OCP$ (by geometry)]

$\Rightarrow S_1P = PM \Rightarrow S_2P = S_2M$

If θ is small, then $\sin \theta \approx \theta \approx \tan \theta$

\therefore Path difference,

$S_2P - S_1P = S_2M = d \sin \theta \approx d \tan \theta$

Path difference = $d \left(\frac{y_n}{D} \right)$... (i)

[\because In ΔPCO , $\tan \theta = \frac{OP}{CO} = \frac{y_n}{D}$]

For constructive interference

Path difference = $n\lambda$, where, $n = 0, 1, 2, \dots$

$\frac{dy_n}{D} = n\lambda$ [from Eq. (i)]

$\Rightarrow y_n = \frac{Dn\lambda}{d}$

$\Rightarrow y_{n+1} = \frac{D(n+1)\lambda}{d}$

\therefore Fringe width of dark fringe = $y_{n+1} - y_n$

[\because Dark fringe exist between two bright fringes]

$\beta = \frac{D\lambda}{d}(n+1) - \frac{Dn\lambda}{d} = \frac{d\lambda}{d}(n+1-n) = \frac{D\lambda}{d}$

Fringe width of dark fringe, $\beta = \frac{D\lambda}{d}$... (ii)

For destructive interference

Path difference = $(2n - 1) \frac{\lambda}{2}$, where $n = 1, 2, 3, \dots$

$$\Rightarrow \frac{y'_n d}{D} = (2n - 1) \frac{\lambda}{2} \quad [\text{from Eq. (i)}]$$

$$\Rightarrow y'_n = \frac{(2n - 1) D \lambda}{2d}$$

where, y'_n is the separation of n th order dark fringe from central fringe.

$$\therefore y'_{n+1} = (2n + 1) \frac{D\lambda}{2d} \quad (1)$$

\therefore Fringe width of bright fringe = Separation between $(n + 1)$ th and n th order dark fringe from centred fringe,

$$\Rightarrow \beta = y'_{n+1} - y'_n$$

$$\begin{aligned} \text{or } \beta &= \frac{(2n + 1) D\lambda}{2d} - \frac{(2n - 1) D\lambda}{2d} \\ &= \frac{D\lambda}{2d} [2n + 1 - 2n + 1] = \frac{D\lambda}{2d} \quad [2] \end{aligned}$$

Fringe width of bright fringe, $\beta = \frac{D\lambda}{d}$... (iii)

From Eqs. (ii) and (iii), we can see that, fringe width of dark fringe = fringe width of bright fringe

$$\beta = \frac{D\lambda}{d} \quad (1/2)$$

$$(ii) \text{ Intensity, } I = 4I_0 \cos^2 \frac{\phi}{2} \quad \dots(i)$$

where, I_0 is incident intensity and I is resultant intensity.

At a point where path difference is λ

$$\text{Phase difference, } \phi = \frac{2\pi}{\lambda} \times \lambda = 2\pi$$

Substituting the value of ϕ in Eq.(i), we get

$$I = 4I_0 \cos^2 \frac{2\pi}{2} = 4I_0 \cos^2 \pi = 4I_0 = K$$

At a point where path difference is $\frac{\lambda}{3}$,

Phase difference,

$$\phi = \frac{2\pi}{\lambda} \Delta x = \frac{2\pi}{\lambda} \cdot \frac{\lambda}{3} = \frac{2\pi}{3}$$

$$I_2 = 4I_0 \cos^2 \frac{\phi}{2} = 4 \left(\frac{K}{4} \right) \cos^2 \frac{\pi}{3}$$

$$= 4 \frac{K}{4} \times \frac{1}{4} = \frac{K}{4} \quad (1)$$

22. In Young's double slit experiment, derive the condition for

(a) constructive interference and

(b) destructive interference at a point on the screen.

(ii) A beam of light consisting of two wavelengths, 800 nm and 600 nm is used to obtain the interference fringes on a screen placed 1.4 m away in a Young's double slit experiment. If the two slits are separated by 0.28 mm, calculate the least distance from the central bright

maximum where the bright fringes of the two wavelengths coincide.

[All India 2012]

Ans.(i)

Let two coherent sources of light, S_1 and S_2 (narrow slits) are derived from a source S . The two slits, S_1 and S_2 are equidistant from source, S .

Now, suppose S_1 and S_2 are separated by distance d . The slits and screen are distance D apart.

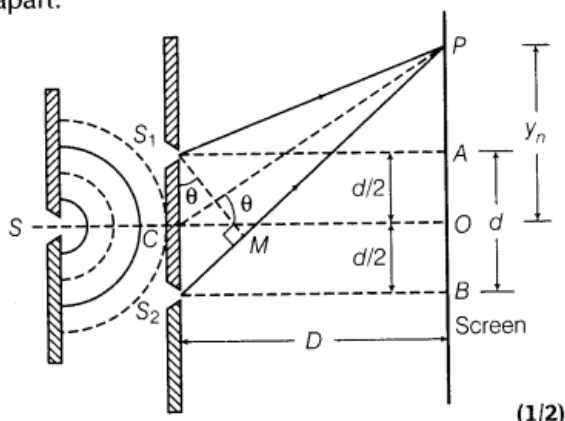

(1/2)

Considering any arbitrary point P on the screen at a distance y_n from the centre O .

The path difference between interfering waves is given by $S_2P - S_1P$

$$\text{i.e. Path difference} = S_2P - S_1P = S_2M$$

$$S_2P - S_1P = d \sin \theta$$

$$\text{where, } S_1M \perp S_2P \quad (1)$$

$$[\because \angle S_2S_1M = \angle OCP \text{ (by geometry)}]$$

$$\Rightarrow S_1P = PM \Rightarrow S_2P = S_2M]$$

If θ is small, then $\sin \theta \approx \theta \approx \tan \theta$

\therefore Path difference,

$$S_2P - S_1P = S_2M = d \sin \theta \approx d \tan \theta$$

$$\text{Path difference} = d \left(\frac{y_n}{D} \right) \quad \dots(i)$$

$$[\because \text{In } \triangle PCO, \tan \theta = \frac{OP}{CO} = \frac{y_n}{D}]$$

For constructive interference

Path difference = $n\lambda$, where, $n = 0, 1, 2, \dots$

$$\frac{dy_n}{D} = n\lambda \quad [\text{from Eq. (i)}]$$

$$\Rightarrow y_n = \frac{Dn\lambda}{d}$$

$$\Rightarrow y_{n+1} = \frac{D(n+1)\lambda}{d}$$

\therefore Fringe width of dark fringe = $y_{n+1} - y_n$

[\because Dark fringe exist between two bright fringes]

$$\beta = \frac{D\lambda}{d}(n+1) - \frac{Dn\lambda}{d} = \frac{d\lambda}{d}(n+1-n) = \frac{D\lambda}{d}$$

$$\text{Fringe width of dark fringe, } \beta = \frac{D\lambda}{d} \quad \dots(ii)$$

For destructive interference

Path difference = $(2n - 1) \frac{\lambda}{2}$, where $n = 1, 2, 3, \dots$

$$\Rightarrow \frac{y'_n d}{D} = (2n - 1) \frac{\lambda}{2} \quad [\text{from Eq. (i)}]$$

$$\Rightarrow y'_n = \frac{(2n - 1) D \lambda}{2d}$$

where, y'_n is the separation of n th order dark fringe from central fringe.

$$\therefore y'_{n+1} = (2n + 1) \frac{D\lambda}{2d} \quad (1)$$

\therefore Fringe width of bright fringe = Separation between $(n + 1)$ th and n th order dark fringe from centred fringe,

$$\Rightarrow \beta = y'_{n+1} - y'_n$$

$$\begin{aligned} \text{or } \beta &= \frac{(2n + 1) D\lambda}{2d} - \frac{(2n - 1) D\lambda}{2d} \\ &= \frac{D\lambda}{2d} [2n + 1 - 2n + 1] = \frac{D\lambda}{2d} \quad [2] \end{aligned}$$

Fringe width of bright fringe, $\beta = \frac{D\lambda}{d}$... (iii)

From Eqs. (ii) and (iii), we can see that, fringe width of dark fringe = fringe width of bright fringe

$$\beta = \frac{D\lambda}{d} \quad (1/2)$$

(ii) Given, $\lambda_1 = 800 \text{ nm}$, $\lambda_2 = 600 \text{ nm}$

$$\begin{aligned} D &= 1.4 \text{ m and } d = 0.28 \text{ mm} \\ &= 2.8 \times 10^{-4} \text{ m} \end{aligned}$$

Let n th order bright fringe of $\lambda = 800 \text{ nm}$ coincide with $(n + 1)$ th order 600 nm wavelength.

$$\therefore \frac{Dn\lambda_1}{d} = \frac{D(n+1)\lambda_2}{d} \quad (1/2)$$

$$\Rightarrow n\lambda_1 = (n+1)\lambda_2 \quad (1/2)$$

$$n \times 800 \times 10^{-9} = (n+1) \times 600 \times 10^{-9}$$

$$\frac{n+1}{n} = \frac{4}{3}$$

$$\frac{1}{n} = \frac{4}{3} - 1 = \frac{1}{3}$$

$$n = 3 \quad (1/2)$$

\therefore Least distance from central fringe,

$$y_n = \frac{Dn\lambda_1}{d}$$

$$y_n = \frac{1.4 \times 3 \times 800 \times 10^{-9}}{2.8 \times 10^{-4}}$$

$$= 12 \times 10^{-3} \text{ m}$$

$$y_n = 12 \text{ mm}$$

23.(i) What is the effect on the interference fringes to a Young's double slit experiment when (a) the separation between the two slits is decreased?

(b) the width of the source-slit is increased?

(c) the monochromatic source is replaced by a source of white light? Justify your answer in each case

(ii) The intensity at the central maxima in Young's double slit experimental set up is I_0 . Show that the intensity at a point where the path difference is $\lambda/3$, is $I_0/4$.

[Foreign 2012]

Ans.

(i) (a) From the fringe width expression,

$$\beta = \frac{\lambda D}{d}$$

With the decrease in separation between two slits, the fringe width β increases. (1)

(b) For interference fringes to be seen,

$$\frac{s}{S} < \frac{\lambda}{d}$$

Condition should be satisfied

where, s = size of the source,

S = distance of the source from the plane of two slits.

As, the source slit width increases, fringe pattern gets less and less sharp.

When the source slit is so wide, the above condition does not satisfied and the interference pattern disappears. (1)

(c) The interference pattern due to different colour component of white light overlap. The central bright fringes for different colours are at the same position. Therefore, central fringe is white. And on the either side of the central white fringe (i.e. central maxima), coloured bands will appear. The fringe closed on either side of central white fringe is red and the farthest will be blue. After a few fringes, no clear fringe pattern is seen.

(1)

(ii) Intensity at a point is given by

$$I = 4I' \cos^2 \phi / 2$$

where, ϕ = phase difference,

I' = intensity produced by each one of the individual sources.

At central maxima, $\phi = 0$, the intensity at the central maxima, $I = I_0 = 4I'$

or
$$I' = \frac{I_0}{4} \quad \dots(i)$$

As, path difference = $\frac{\lambda}{3}$

Phase difference,

$$\phi' = \frac{2\pi}{\lambda} \times \text{path difference}$$

$$= \frac{2\pi}{\lambda} \times \frac{\lambda}{3} = \frac{2\pi}{3}$$

Now, intensity at this point

$$I'' = 4I' \cos^2 \frac{1}{2} \left(\frac{2\pi}{3} \right) = 4I' \cos^2 \frac{\pi}{3}$$

$$= 4I' \times \frac{1}{4} = I'$$

or
$$I'' = \frac{I_0}{4} \quad [\text{from Eq. (i)}]$$

24. State the importance of coherent sources in the phenomenon of interference. In Young's double slit experiment to produce interference pattern, obtain the conditions for constructive and destructive interference. Hence, deduce the expression for the fringe width. How does the fringe width get affected, if the entire experimental apparatus of YDSE is immersed in water? [All India 2011]

Ans. To observe interference fringe pattern, there is need to have coherent sources of light which can produce light of constant phase difference

Let two coherent sources of light, S_1 and S_2 (narrow slits) are derived from a source S . The two slits, S_1 and S_2 are equidistant from source, S .

Now, suppose S_1 and S_2 are separated by distance d . The slits and screen are distance D apart.

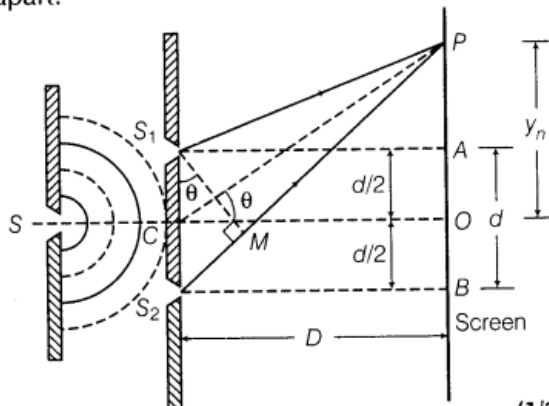

(1/2)

Considering any arbitrary point P on the screen at a distance y_n from the centre O .
The path difference between interfering waves is given by $S_2P - S_1P$

$$\begin{aligned} \text{i.e. Path difference} &= S_2P - S_1P = S_2M \\ S_2P - S_1P &= d \sin \theta \\ \text{where, } S_1M &\perp S_2P \quad (1) \end{aligned}$$

$$\begin{aligned} [\because \angle S_2S_1M &= \angle OCP \text{ (by geometry)} \\ \Rightarrow S_1P &= PM \Rightarrow S_2P = S_2M] \end{aligned}$$

If θ is small, then $\sin \theta \approx \theta \approx \tan \theta$

\therefore Path difference,

$$S_2P - S_1P = S_2M = d \sin \theta \approx d \tan \theta$$

$$\text{Path difference} = d \left(\frac{y_n}{D} \right) \quad \dots(i)$$

$$[\because \text{In } \triangle PCO, \tan \theta = \frac{OP}{CO} = \frac{y_n}{D}]$$

For constructive interference

Path difference = $n\lambda$, where, $n = 0, 1, 2, \dots$

$$\frac{dy_n}{D} = n\lambda \quad [\text{from Eq. (i)}]$$

$$\Rightarrow y_n = \frac{Dn\lambda}{d}$$

$$\Rightarrow y_{n+1} = \frac{D(n+1)\lambda}{d}$$

\therefore Fringe width of dark fringe = $y_{n+1} - y_n$

[\because Dark fringe exist between two bright fringes]

$$\beta = \frac{D\lambda}{d}(n+1) - \frac{Dn\lambda}{d} = \frac{d\lambda}{d}(n+1-n) = \frac{D\lambda}{d}$$

$$\text{Fringe width of dark fringe, } \beta = \frac{D\lambda}{d} \quad \dots(ii)$$

For destructive interference

Path difference = $(2n-1)\frac{\lambda}{2}$, where $n = 1, 2, 3, \dots$

$$\Rightarrow \frac{y'_n d}{D} = (2n-1)\frac{\lambda}{2} \quad [\text{from Eq. (i)}]$$

$$\Rightarrow y'_n = \frac{(2n-1)D\lambda}{2d}$$

where, y'_n is the separation of n th order dark fringe from central fringe.

$$\therefore y'_{n+1} = (2n+1)\frac{D\lambda}{2d} \quad (1)$$

\therefore Fringe width of bright fringe = Separation between $(n+1)$ th and n th order dark fringe from centred fringe,

$$\Rightarrow \beta = y'_{n+1} - y'_n$$

$$\begin{aligned} \text{or } \beta &= \frac{(2n+1)D\lambda}{2d} - \frac{(2n-1)D\lambda}{2d} \\ &= \frac{D\lambda}{2d} [2n+1 - 2n+1] = \frac{D\lambda}{2d} [2] \end{aligned}$$

$$\text{Fringe width of bright fringe, } \beta = \frac{D\lambda}{d} \quad \dots(\text{iii})$$

From Eqs. (ii) and (iii), we can see that,
fringe width of dark fringe = fringe width of bright fringe

$$\beta = \frac{D\lambda}{d} \quad (1/2)$$

(ii) In this case, the light of blue colour interfere destructively and hence this colour would subtract from white light. Thus, yellow colour fringe would be obtained at P.

25. What are coherent sources? Why are they necessary for observing a sustained interference pattern? How are the two coherent sources obtained in the Young's double slit experiment?

(ii) Show that the superposition of the waves originating from the two coherent sources, S_1 and S_2 having displacement, $y_1 = a \cos \omega t$ and $y_2 = a \cos(\omega t + \phi)$ at a point produce a resultant intensity,

$$I = 4a^2 \cos^2 \phi / 2$$

Hence, write the conditions for the appearance of dark and bright fringes.

[All India 2010C]

Ans. (i) Two monochromatic sources, which produce light waves, having a constant phase difference are known as coherent sources.

Given,

$$y_1 = a \cos \omega t$$

$$y_2 = a \cos(\omega t + \phi)$$

(a) The resultant displacement is given by

$$\begin{aligned} Y &= y_1 + y_2 \\ &= a \cos \omega t + a \cos(\omega t + \phi) \\ &= a \cos \omega t + a \cos \omega t \cos \phi - a \sin \omega t \sin \phi \\ &= a \cos \omega t (1 + \cos \phi) - a \sin \omega t \sin \phi \end{aligned}$$

$$\text{Put } R \cos \theta = a(1 + \cos \phi) \quad \dots(\text{i})$$

$$R \sin \theta = a \sin \phi \quad \dots(\text{ii})$$

By squaring and adding Eqs. (i) and (ii), we get

$$\begin{aligned} R^2 &= a^2(1 + \cos^2 \phi + 2 \cos \phi) + a^2 \sin^2 \phi \\ &= 2a^2(1 + \cos \phi) \\ &= 4a^2 \cos^2 \frac{\phi}{2} \end{aligned}$$

$$\begin{aligned} \therefore I &= R^2 = 4a^2 \cos^2 \frac{\phi}{2} \\ &= 4I_0 \cos^2 \frac{\phi}{2} \end{aligned}$$

(b) For constructive interference,

$$\cos \frac{\phi}{2} = \pm 1 \text{ or}$$

$$\frac{\phi}{2} = n\pi \text{ or}$$

$$\phi = 2n\pi$$

For destructive interference,

$$\cos \frac{\phi}{2} = 0 \text{ or}$$

$$\frac{\phi}{2} = (2n + 1) \frac{\pi}{2} \text{ or}$$

$$\phi = (2n + 1)\pi$$

(ii)

Let two coherent sources of light, S_1 and S_2 (narrow slits) are derived from a source S . The two slits, S_1 and S_2 are equidistant from source, S .

Now, suppose S_1 and S_2 are separated by distance d . The slits and screen are distance D apart.

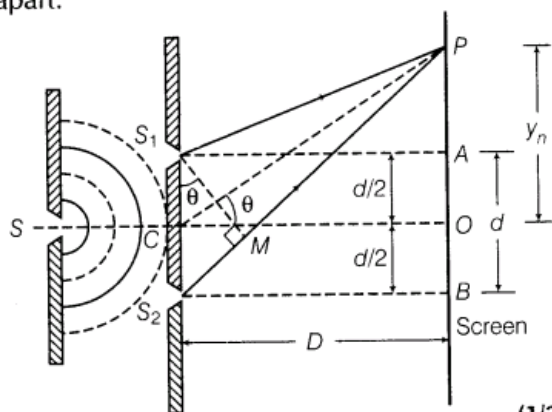

(1/2)

Considering any arbitrary point P on the screen at a distance y_n from the centre O .

The path difference between interfering waves is given by $S_2P - S_1P$

i.e. Path difference = $S_2P - S_1P = S_2M$

$$S_2P - S_1P = d \sin \theta$$

where, $S_1M \perp S_2P$ (1)

[$\because \angle S_2S_1M = \angle OCP$ (by geometry)]

$$\Rightarrow S_1P = PM \Rightarrow S_2P = S_2M$$

If θ is small, then $\sin \theta \approx \theta \approx \tan \theta$

\therefore Path difference,

$$S_2P - S_1P = S_2M = d \sin \theta \approx d \tan \theta$$

$$\text{Path difference} = d \left(\frac{y_n}{D} \right) \quad \dots(i)$$

$$[\because \text{In } \triangle PCO, \tan \theta = \frac{OP}{CO} = \frac{y_n}{D}]$$

For constructive interference

Path difference = $n\lambda$, where, $n = 0, 1, 2, \dots$

$$\frac{dy_n}{D} = n\lambda \quad \text{[from Eq. (i)]}$$

$$\Rightarrow y_n = \frac{Dn\lambda}{d}$$

$$\Rightarrow y_{n+1} = \frac{D(n+1)\lambda}{d}$$

\therefore Fringe width of dark fringe = $y_{n+1} - y_n$

[\therefore Dark fringe exist between two bright fringes]

$$\beta = \frac{D\lambda}{d}(n+1) - \frac{Dn\lambda}{d} = \frac{d\lambda}{d}(n+1-n) = \frac{D\lambda}{d}$$

Fringe width of dark fringe, $\beta = \frac{D\lambda}{d}$... (ii)

For destructive interference

Path difference = $(2n-1)\frac{\lambda}{2}$, where $n = 1, 2, 3, \dots$

$$\Rightarrow \frac{y'_n d}{D} = (2n-1)\frac{\lambda}{2} \quad \text{[from Eq. (i)]}$$

$$\Rightarrow y'_n = \frac{(2n-1)D\lambda}{2d}$$

where, y'_n is the separation of n th order dark fringe from central fringe.

$$\therefore y'_{n+1} = (2n+1)\frac{D\lambda}{2d} \quad (1)$$

\therefore Fringe width of bright fringe = Separation between $(n+1)$ th and n th order dark fringe from centred fringe,

$$\Rightarrow \beta = y'_{n+1} - y'_n$$

or
$$\beta = \frac{(2n+1)D\lambda}{2d} - \frac{(2n-1)D\lambda}{2d}$$
$$= \frac{D\lambda}{2d} [2n+1 - 2n+1] = \frac{D\lambda}{2d} [2]$$

Fringe width of bright fringe, $\beta = \frac{D\lambda}{d}$... (iii)

From Eqs. (ii) and (iii), we can see that, fringe width of dark fringe = fringe width of bright fringe

$$\beta = \frac{D\lambda}{d} \quad (1/2)$$

Condition for bright fringe or constructive interference

$$\cos\left(\frac{\phi}{2}\right) = \pm 1, \quad \text{then, } I = I_0 = 4a^2$$

$$\Rightarrow \frac{\phi}{2} = n\pi$$

$$\phi = 2n\pi$$

Also path difference = $\frac{\lambda}{2\pi} \times$ Phase difference

or $x = \frac{\lambda}{2\pi} \times 2n\pi$

Path difference, $x = n\lambda$

Bright fringe obtained when path difference of interfering wave is $n\lambda$ and phase difference is $2n\pi$. (1)

Condition for dark fringe or destructive interference

$$I = 0 \Rightarrow \cos\frac{\phi}{2} = 0$$

or $\cos\frac{\phi}{2} = 0 = \cos(2n+1)\frac{\pi}{2}$

$$\Rightarrow \frac{\phi}{2} = (2n+1)\frac{\pi}{2}, \quad \text{where } n = 0, 1, 2, \dots$$

$$\Rightarrow \phi = (2n+1)\pi, \quad n = 0, 1, 2, \dots$$

Path difference,

$$x = \frac{\lambda}{2\pi} \times \phi = \frac{\lambda}{2\pi} \times (2n+1)\pi$$

$$x = (2n+1)\frac{\lambda}{2}$$

Path difference, $x = (2n+1)\frac{\lambda}{2}$

Dark fringes obtained when interfering wave have path difference is odd multiple of $\frac{\lambda}{2}$ and phase difference is odd multiple of π . (2)

26. In a Young's double slit experiment,

(i) deduce the conditions for constructive and destructive interference. Hence, write the expression for the distance between two consecutive bright or dark fringe.

(ii) what change in the interference pattern do you observe, if the two slits, S_1 and S_2 are taken as point sources?

(iii) plot a graph of the intensity distribution versus path difference in this experiment.

Compare this with the intensity distribution of fringes due to diffraction at a single slit. What important difference do you observe? [Delhi 2009 c]

Ans. (i)

Let two coherent sources of light, S_1 and S_2 (narrow slits) are derived from a source S . The two slits, S_1 and S_2 are equidistant from source, S .

Now, suppose S_1 and S_2 are separated by distance d . The slits and screen are distance D apart.

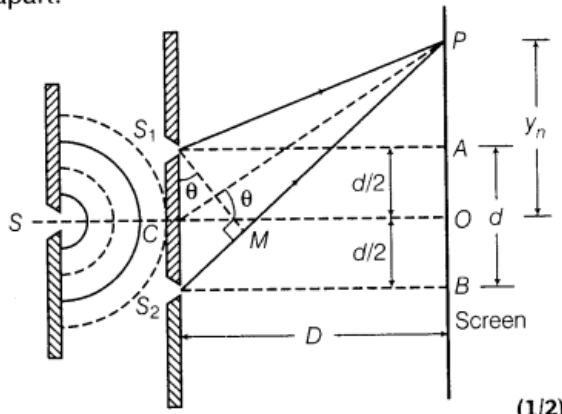

Considering any arbitrary point P on the screen at a distance y_n from the centre O . The path difference between interfering waves is given by $S_2P - S_1P$

i.e. Path difference = $S_2P - S_1P = S_2M$
 $S_2P - S_1P = d \sin \theta$
 where, $S_1M \perp S_2P$ (1)
 $[\because \angle S_2S_1M = \angle OCP \text{ (by geometry)}]$
 $\Rightarrow S_1P = PM \Rightarrow S_2P = S_2M]$
 If θ is small, then $\sin \theta \approx \theta \approx \tan \theta$
 \therefore Path difference,
 $S_2P - S_1P = S_2M = d \sin \theta \approx d \tan \theta$
 Path difference = $d \left(\frac{y_n}{D} \right)$... (i)

$[\because \text{In } \Delta PCO, \tan \theta = \frac{OP}{CO} = \frac{y_n}{D}]$

For constructive interference

Path difference = $n\lambda$, where, $n = 0, 1, 2, \dots$

$\frac{dy_n}{D} = n\lambda$ [from Eq. (i)]
 $\Rightarrow y_n = \frac{Dn\lambda}{d}$
 $\Rightarrow y_{n+1} = \frac{D(n+1)\lambda}{d}$

\therefore Fringe width of dark fringe = $y_{n+1} - y_n$

[\because Dark fringe exist between two bright fringes]

$\beta = \frac{D\lambda}{d}(n+1) - \frac{Dn\lambda}{d} = \frac{d\lambda}{d}(n+1-n) = \frac{D\lambda}{d}$

Fringe width of dark fringe, $\beta = \frac{D\lambda}{d}$... (ii)

For destructive interference

Path difference = $(2n - 1) \frac{\lambda}{2}$, where $n = 1, 2, 3, \dots$

$$\Rightarrow \frac{y'_n d}{D} = (2n - 1) \frac{\lambda}{2} \quad [\text{from Eq. (i)}]$$

$$\Rightarrow y'_n = \frac{(2n - 1) D \lambda}{2d}$$

where, y'_n is the separation of n th order dark fringe from central fringe.

$$\therefore y'_{n+1} = (2n + 1) \frac{D\lambda}{2d} \quad (1)$$

\therefore Fringe width of bright fringe = Separation between $(n + 1)$ th and n th order dark fringe from centred fringe,

$$\Rightarrow \beta = y'_{n+1} - y'_n$$

$$\begin{aligned} \text{or } \beta &= \frac{(2n + 1) D\lambda}{2d} - \frac{(2n - 1) D\lambda}{2d} \\ &= \frac{D\lambda}{2d} [2n + 1 - 2n + 1] = \frac{D\lambda}{2d} \quad [2] \end{aligned}$$

Fringe width of bright fringe, $\beta = \frac{D\lambda}{d}$... (iii)

From Eqs. (ii) and (iii), we can see that, fringe width of dark fringe = fringe width of bright fringe

$$\beta = \frac{D\lambda}{d} \quad (1/2)$$

 To find the point of coincidence of bright fringes, we can equate the distance of bright fringes from the central maxima, made by both the wavelengths of light

Given, $D = 1 \text{ m}$, $d = 4 \times 10^{-3} \text{ m}$, $\lambda_1 = 560 \text{ nm}$, and $\lambda_2 = 420 \text{ nm}$

Let n th order bright fringe of λ_1 coincides with $(n + 1)$ th order bright fringe of λ_2 .

$$\Rightarrow \frac{Dn\lambda_1}{d} = \frac{D(n + 1)\lambda_2}{d} \quad (\lambda_1 > \lambda_2)$$

$$\Rightarrow n\lambda_1 = (n + 1)\lambda_2 \quad (1)$$

$$\Rightarrow \frac{n + 1}{n} = \frac{\lambda_1}{\lambda_2}$$

$$1 + \frac{1}{n} = \frac{560 \times 10^{-9}}{420 \times 10^{-9}}$$

$$\Rightarrow 1 + \frac{1}{n} = \frac{4}{3}$$

$$\Rightarrow \frac{1}{n} = \frac{1}{3} \Rightarrow n = 3 \quad (1)$$

\therefore Least distance from the central fringe where bright fringe of two wavelength coincides.

= Distance of 3rd order bright fringe of λ_1

$$\Rightarrow y_n = \frac{3D\lambda_1}{d}$$

$$= \frac{3 \times 1 \times 560 \times 10^{-9}}{4 \times 10^{-3}}$$

$$y_n = 420 \times 10^{-6} \text{ m}$$

$$= 0.42 \times 10^{-3} \text{ m}$$

$$\therefore y_n = 0.42 \text{ mm} \quad (1)$$

Thus, 3rd bright fringe of λ_1 and 4th bright fringe of λ_2 coincide at 0.42 mm from central fringe.

(ii) Being two independent sources, the difference between the waves from two sources is not constant and hence interference pattern cannot be seen on screen.

(iii) Graph of the intensity distribution versus path difference

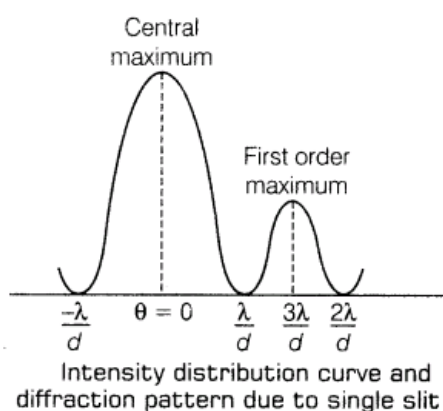
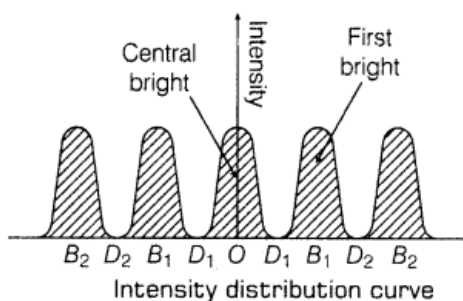

The intensity of bright fringes in interference is same for all the bright fringes whereas in diffraction pattern, the central fringe is brightest and intensity of secondary maxima decreases with the increase of their order.

27.(i) What are coherent sources of light? Two slits in Young's double slit experiment are illuminated by two different sodium lamps emitting light of the same wavelength. Why does no interference pattern observed?

(ii) Obtain the condition for getting dark and bright fringes in Young's experiment. Hence, write the expression for the fringe width.

(iii) If s is the size of the source and d be its distance from the plane of the two slits. What should be the criterion for the interference fringes to be seen. [HOTS; Delhi 2006]

Ans.

? Here concept of superposition will be used i.e. disturbance at a point will be equal to displacement produced by individual sources.

(i) Coherent sources of light Refer to Ans -1 Two different sodium lamps cannot produce interference fringe pattern as they are unable to maintain constant initial phase difference

between them.

(ii) Let two interfering waves at any point in the region of superposition are given by

$$y_1 = a \sin \omega t, \text{ and}$$

$$y_2 = a \sin (\omega t + \phi)$$

By principle of superposition of waves,

$$y = y_1 + y_2$$

$$y = a_1 \sin \omega t + a_2 \sin (\omega t + \phi)$$

$$= a_1 \sin \omega t + a_2 \sin \omega t \cos \phi$$

$$+ a_2 \cos \omega t \sin \phi$$

$$y = (a_1 + a_2 \cos \phi) \sin \omega t + (a_2 \sin \phi) \cos \omega t$$

$$\text{or } y = A \cos \theta \sin \omega t + A \sin \theta \cos \omega t \quad (1)$$

$$\text{where, } A \cos \theta = a_1 + a_2 \cos \phi \quad \dots(i)$$

$$\text{and } A \sin \theta = a_2 \sin \phi \quad \dots(ii)$$

$$\Rightarrow y = A (\sin \omega t \cos \theta + \cos \omega t \sin \theta)$$

$$y = A \sin (\omega t + \theta) \quad \dots(iii)$$

where, A is the resultant amplitude of interfering waves.

Now, squaring and adding Eqs. (i) and (ii), we get

$$(A \cos \theta)^2 + (A \sin \theta)^2 = (a_1 + a_2 \cos \phi)^2 + (a_2 \sin \phi)^2$$

$$A^2 (\cos^2 \theta + \sin^2 \theta) = a_1^2 + a_2^2 \cos^2 \phi + 2a_1a_2 \cos \phi + a_2^2 \sin^2 \phi$$

$$A^2 = a_1^2 + a_2^2 (\cos^2 \phi + \sin^2 \phi) + 2a_1a_2 \cos \phi$$

$$A^2 = a_1^2 + a_2^2 + 2a_1a_2 \cos \phi \quad \dots(iv)$$

For constructive interference

$$A = A_{\max} \Rightarrow \cos \phi = +1$$

$$\Rightarrow \phi = 2n\pi \quad \text{where, } n = 0, 1, 2, \dots$$